



Standard Specification for Stainless Steel Spring Wire¹

This standard is issued under the fixed designation A313/A313M; the number immediately following the designation indicates the year of original adoption or, in the case of revision, the year of last revision. A number in parentheses indicates the year of last reappraisal. A superscript epsilon (ϵ) indicates an editorial change since the last revision or reappraisal.

This standard has been approved for use by agencies of the U.S. Department of Defense.

1. Scope*

1.1 This specification covers austenitic, austenitic-ferritic, and age-hardenable stainless steel round spring wire intended especially for the manufacture of springs.

1.2 The values stated in either SI units or inch-pound units are to be regarded separately as standard. The values stated in each system may not be exact equivalents; therefore, each system shall be used independently of the other. Combining values from the two systems may result in non-conformance with the standard.

1.3 Unless the order specifies an “M” designation, the material shall be furnished to inch-pound units.

2. Referenced Documents

2.1 ASTM Standards:²

[A555/A555M Specification for General Requirements for Stainless Steel Wire and Wire Rods](#)

[A751 Test Methods, Practices, and Terminology for Chemical Analysis of Steel Products](#)

[E527 Practice for Numbering Metals and Alloys in the Unified Numbering System \(UNS\)](#)

2.2 Society of Automotive Engineers Standard:³

[J 1086 Numbering Metals and Alloys](#)

3. Ordering Information

3.1 It is the responsibility of the purchaser to specify all requirements that are necessary for material ordered under this specification. Such requirements may include, but are not limited to the following:

3.1.1 Quantity (weight),

¹ This specification is under the jurisdiction of ASTM Committee A01 on Steel, Stainless Steel and Related Alloys and is the direct responsibility of Subcommittee A01.17 on Flat-Rolled and Wrought Stainless Steel.

Current edition approved Oct. 1, 2013. Published October 2013. Originally approved in 1947. Last previous edition approved in 2010 as A313/A313M – 10^{ε1}. DOI: 10.1520/A0313_A0313M-13.

² For referenced ASTM standards, visit the ASTM website, www.astm.org, or contact ASTM Customer Service at service@astm.org. For *Annual Book of ASTM Standards* volume information, refer to the standard's Document Summary page on the ASTM website.

³ Available from Society of Automotive Engineers (SAE), 400 Commonwealth Dr., Warrendale, PA 15096-0001, <http://www.sae.org>.

- 3.1.2 Name of material (stainless steel spring wire),
- 3.1.3 Finish (see 8.1),
- 3.1.4 Dimension (diameter),
- 3.1.5 Type designation (Table 1),
- 3.1.6 ASTM designation and date of issue,
- 3.1.7 Tensile strength level, when applicable (Table 11 and Table 12),
- 3.1.8 Supplementary requirements for government procurement, and
- 3.1.9 Special requirements.

NOTE 1—A typical ordering description is as follows:

2000 lb (1000 kg) Stainless Steel Spring Wire, cold-drawn Class 1, bright finish, 0.032-in. (0.82 mm) diameter, in 100-lb (50 kg) 16-in. (0.4 m) coils, Type 302 to ASTM A313, dated ____.

4. General Requirements for Delivery

4.1 In addition to the requirements of this specification, all requirements of the current edition of Specification [A555/A555M](#) shall apply. Failure to comply with the general requirements of Specification [A555/A555M](#) constitutes non-conformance with this specification.

5. Manufacture

5.1 Types 302 Class 1, 304, 305, 316, 321, 347, UNS S20230, and Grades S20430 and XM-28 shall be cold drawn to produce the required mechanical properties.

5.2 Type 631, Type 302 Class 2, and Grade XM-16 shall be furnished in the cold-drawn condition ready for fabrication. Following fabrication Type 631 and Grade XM-16 shall be age or precipitation hardened to produce their maximum strength properties. The tensile strengths to be obtained following the prescribed heat treatment are shown in [Table 2](#) and [Table 3](#) for hardened wire. Type 302 Class 2 shall be stress relieved following fabrication and meet the requirements shown in [Table 4](#). The nominal as-drawn tensile strengths are provided as a guide for the spring manufacturer.

5.3 Grade S30151 shall be either cold drawn or cold drawn and heat treated to produce the required mechanical properties.

6. Chemical Composition

6.1 The steel shall conform to the requirements as to chemical composition prescribed in [Table 1](#).

*A Summary of Changes section appears at the end of this standard

TABLE 1 Chemical Requirements

UNS Designation ^A	Type	Composition, ^B %									
		Carbon	Manganese	Phosphorus	Sulfur	Silicon	Chromium	Nickel	Molybdenum	Nitrogen	Other Elements
Austenitic Grades											
S 24100	XM-28	0.15	11.0–14.0	0.060	0.030	1.00	16.5–19.0	0.50–2.50		0.20–0.45	
S 30200	302	0.12	2.00	0.045	0.030	1.00	17.0–19.0	8.0–10.0		0.10	
S 30400	304	0.08	2.00	0.045	0.030	1.00	18.0–20.0	8.0–10.5		0.10	
S 30500	305	0.12	2.00	0.045	0.030	1.00	17.0–19.0	10.5–13.0			
S 31600	316	0.07	2.00	0.045	0.030	1.00	16.5–18.0	10.5–13.5	2.00–2.50	0.10	
S 32100	321	0.08	2.00	0.045	0.030	1.00	17.0–19.0	9.0–12.0			Ti 5×C min (Cb + Ta)
S 34700	347	0.08	2.00	0.045	0.030	1.00	17.0–19.0	9.0–13.0			10×C min
S 30151		0.07–0.09	1.50–2.00	0.025	0.010	1.20–1.80	16.0–18.0	7.0–9.0	0.50–1.00	0.07–0.11	Cu 0.40 max
S 20230		0.02–0.06	2.0–6.0	0.045	0.030	1.00	17.0–19.0	2.0–4.5	1.0	0.13–0.25	Cu 2.0–4.0
Age-Hardenable Grades											
S 17700	631	0.09	1.00	0.040	0.030	1.00	16.0–18.0	6.5–7.8			Al 0.75–1.50
S 45500	XM-16	0.05	0.50	0.040	0.030	0.50	11.0–12.5	7.5–9.5	0.50 max		Ti 0.80–1.40 Cu 1.50–2.50 (Cb + Ta) 0.10–0.50
S 20430	...	0.15	6.5–9.0	0.060	0.030	1.00	15.5–17.5	1.5–3.5		0.05–0.25	Cu 2.0–4.0
Austenitic-Ferritic Grades											
S32205	...	0.030	2.00	0.030	0.020	1.00	22.0–23.0	4.5–6.5	3.00–3.50	0.14–0.20	

^A New designations established in accordance with Practice E527 and SAE J 1086, Practice for Numbering Metals and Alloys (UNS).

^B Maximum unless range is shown.

TABLE 2 Tensile Strength Requirements for Type 631^A

Diameter, in. [mm]	Cold Drawn Condition		Condition CH-900 ^B , ksi [MPa]	
	C, ksi [MPa]			
	Nominal		min	max
0.010 [0.25] to 0.015 [0.38], incl	295	[2035]	335	[2310]
Over 0.015 [0.38] to 0.020 [0.51], incl	290	[2000]	330	[2275]
Over 0.020 [0.51] to 0.029 [0.74], incl	285	[1965]	325	[2240]
Over 0.029 [0.74] to 0.041 [1.04], incl	275	[1895]	320	[2205]
Over 0.041 [1.04] to 0.051 [1.30], incl	270	[1860]	310	[2135]
Over 0.051 [1.30] to 0.061 [1.55], incl	265	[1825]	305	[2100]
Over 0.061 [1.55] to 0.071 [1.80], incl	257	[1770]	297	[2050]
Over 0.071 [1.80] to 0.086 [2.18], incl	255	[1760]	292	[2015]
Over 0.086 [2.18] to 0.090 [2.29], incl	245	[1690]	282	[1945]
Over 0.090 [2.29] to 0.100 [2.54], incl	242	[1670]	279	[1925]
Over 0.100 [2.54] to 0.106 [2.69], incl	238	[1640]	274	[1890]
Over 0.106 [2.69] to 0.130 [3.30], incl	236	[1625]	272	[1875]
Over 0.130 [3.30] to 0.138 [3.50], incl	230	[1585]	260	[1795]
Over 0.138 [3.50] to 0.146 [3.71], incl	228	[1570]	258	[1780]
Over 0.146 [3.71] to 0.162 [4.11], incl	226	[1560]	256	[1765]
Over 0.162 [4.11] to 0.180 [4.57], incl	224	[1545]	254	[1750]
Over 0.180 [4.57] to 0.207 [5.26], incl	222	[1530]	252	[1740]
Over 0.207 [5.26] to 0.225 [5.72], incl	218	[1505]	248	[1710]
Over 0.225 [5.72] to 0.306 [7.77], incl	213	[1470]	242	[1670]
Over 0.306 [7.77] to 0.440 [11.2], incl	207	[1425]	235	[1620]
Over 0.440 [11.2] to 0.625 [15.88], incl	203	[1400]	230	[1585]

^A When wire is specified in straightened and cut lengths, the minimum tensile strength shall be 90 % of the values listed in the table.

^B Aged at 900°F [482°C] for 1 h and air cooled.

6.2 Methods and practices relating to chemical analysis required by this specification shall be in accordance with Test Methods, Practices, and Terminology A751.

7. Mechanical Requirements

7.1 Tensile Properties:

7.1.1 Types 302 Class 1 and 304 shall conform to the requirements shown in Table 5.

7.1.2 Types 305, 316, 321, and 347 shall conform to the requirements shown in Table 6.

7.1.3 Type 631 shall conform to the requirements shown in Table 2 when heat treated 900°F [482°C] for 1 h and air cooled.

TABLE 3 Tensile Strength Requirements for Grade XM-16^A

Diameter, in. [mm]	Cold Drawn, ksi [MPa] Nominal	Age Hardened ^B , ksi [MPa]	
		min	max
0.010 [0.25] to 0.040 [1.02], incl	245 [1690]	320 [2205]	350 [2415]
Over 0.040 [1.02] to 0.050 [1.27], incl	235 [1620]	310 [2135]	340 [2345]
Over 0.050 [1.27] to 0.060 [1.52], incl	225 [1550]	305 [2100]	335 [2310]
Over 0.060 [1.52] to 0.075 [1.90], incl	220 [1515]	295 [2035]	325 [2240]
Over 0.075 [1.90] to 0.085 [2.16], incl	215 [1480]	290 [2000]	320 [2205]
Over 0.085 [2.16] to 0.095 [2.41], incl	210 [1450]	285 [1965]	315 [2170]
Over 0.095 [2.41] to 0.110 [2.79], incl	200 [1380]	278 [1915]	308 [2125]
Over 0.110 [2.79] to 0.125 [3.17], incl	195 [1345]	272 [1875]	302 [2080]
Over 0.125 [3.17] to 0.150 [3.81], incl	190 [1310]	265 [1825]	295 [2035]
Over 0.150 [3.81] to 0.500 [12.7], incl	180 [1240]	260 [1795]	290 [2000]

^A When wire is straightened and cut lengths, the minimum tensile strength shall be 90 % of the values listed in the table.

^B Aged at 850°F [454°C] for ½ h and air cooled.

TABLE 4 Tensile Strength Requirement for Type 302 Class 2

Diameter, in. [mm]	ksi [MPa]		
	Cold Drawn Nominal	Stress Relieved ^A	
		min	max
0.050 [1.30] to 0.160 [4.00], incl	290 [2000]	290 [2000]	340 [2345]

^A Stress relieved at 800 to 850°F [430 to 455°C] for ½ h and air cooled.

7.1.4 Grade XM-16 shall conform to the requirements shown in **Table 3** when heat treated 850°F [454°C] for ½ h and air cooled.

7.1.5 Grade XM-28 shall conform to the requirements shown in **Table 7**.

7.1.6 Type 302 Class 2 shall conform to the requirements shown in **Table 4**.

7.1.7 Grade S20430 shall conform to the requirements shown in **Table 8**.

7.1.8 Cold drawn grade S30151 shall conform to the requirements shown in **Table 9**.

7.1.9 Cold drawn grade UNS S20230 shall conform to the requirements shown in **Table 10**.

7.1.10 Cold drawn, as delivered grade S32205 shall conform to the requirements shown in **Table 11** and **Table 12**.

7.2 Wrap Test:

7.2.1 Wire 0.162 in. [4.11 mm] and smaller in diameter shall wind on itself as an arbor without breaking.

7.2.2 Wire larger than 0.162 in. [4.11 mm] in diameter shall wind without breaking on a mandrel having a diameter twice the diameter of the wire.

7.3 Uniformity (Coil Test):

7.3.1 In the as-cold drawn condition, a specimen coil shall be wound on an arbor of the size specified in **Table 13** to form a tightly wound coil.

7.3.2 After winding, the specimen coil shall be stretched to a permanent set four times its as-wound length. After this treatment, the specimen coil shall show uniform pitch with no splits or fractures.

7.4 *Cast*—A loop or ring shall be cut from the bundle and allowed to fall on the floor. The wire shall lie flat and not spring up or show a wavy condition.

7.5 *Bend Test*—When specified in the purchase order, Types 302, 304, 305, 316, 321, and 347 shall be tested by the bend test. A piece not more than 10 in. [254 mm] long shall be selected from each test sample. These specimens shall be tested in a bending machine conforming substantially to **Fig. 1**. Bends shall be made at as nearly a uniform rate as possible, not exceeding 50 bends per minute, and in no case shall the speed be so great as to cause undue heating of the wire. The test specimen shall be bent back and forth through a total angle of 180° until failure occurs. Each 90° movement in either direction shall be counted as one bend. The wire shall withstand the minimum number of bends specified in **Table 5** and **Table 6**.

8. Finish

8.1 Stainless steel spring wire is supplied with different types of finish such as bright, copper, lead, oxide, and other.

9. Keywords

9.1 austenitic-ferritic duplex; austenitic stainless steel; precipitation hardening stainless steel; stainless steel; stainless steel spring wire



TABLE 5 Tensile Strength Requirements for Types 302 Class 1 and 304^A

Diameter, in. [mm]	Bend Test Minimum Number of Bends	ksi [MPa]	
		min	max
Up to 0.009 [0.23], incl	...	325 [2240]	355 [2450]
Over 0.009 [0.23] to 0.010 [0.25], incl	...	320 [2205]	350 [2415]
Over 0.010 [0.25] to 0.011 [0.28], incl	...	318 [2190]	348 [2400]
Over 0.011 [0.28] to 0.012 [0.30], incl	...	316 [2180]	346 [2385]
Over 0.012 [0.30] to 0.013 [0.33], incl	...	314 [2165]	344 [2370]
Over 0.013 [0.33] to 0.014 [0.36], incl	...	312 [2150]	342 [2360]
Over 0.014 [0.36] to 0.015 [0.38], incl	...	310 [2135]	340 [2345]
Over 0.015 [0.38] to 0.016 [0.41], incl	...	308 [2125]	338 [2330]
Over 0.016 [0.41] to 0.017 [0.43], incl	...	306 [2110]	336 [2315]
Over 0.017 [0.43] to 0.018 [0.46], incl	...	304 [2095]	334 [2300]
Over 0.018 [0.46] to 0.020 [0.51], incl	...	300 [2070]	330 [2275]
Over 0.020 [0.51] to 0.022 [0.56], incl	...	296 [2040]	326 [2250]
Over 0.022 [0.56] to 0.024 [0.61], incl	...	292 [2015]	322 [2220]
Over 0.024 [0.61] to 0.026 [0.66], incl	8	291 [2005]	320 [2205]
Over 0.026 [0.66] to 0.028 [0.71], incl	8	289 [1995]	318 [2190]
Over 0.028 [0.71] to 0.031 [0.79], incl	8	285 [1965]	315 [2170]
Over 0.031 [0.79] to 0.034 [0.86], incl	8	282 [1945]	310 [2135]
Over 0.034 [0.86] to 0.037 [0.94], incl	8	280 [1930]	308 [2125]
Over 0.037 [0.94] to 0.041 [1.04], incl	8	275 [1895]	304 [2095]
Over 0.041 [1.04] to 0.045 [1.14], incl	8	272 [1875]	300 [2070]
Over 0.045 [1.14] to 0.050 [1.27], incl	8	267 [1840]	295 [2035]
Over 0.050 [1.27] to 0.054 [1.37], incl	8	265 [1825]	293 [2020]
Over 0.054 [1.37] to 0.058 [1.47], incl	7	261 [1800]	289 [1990]
Over 0.058 [1.47] to 0.063 [1.60], incl	7	258 [1780]	285 [1965]
Over 0.063 [1.60] to 0.070 [1.78], incl	7	252 [1735]	281 [1935]
Over 0.070 [1.78] to 0.075 [1.90], incl	7	250 [1725]	278 [1915]
Over 0.075 [1.90] to 0.080 [2.03], incl	7	246 [1695]	275 [1895]
Over 0.080 [2.03] to 0.087 [2.21], incl	7	242 [1670]	271 [1870]
Over 0.087 [2.21] to 0.095 [2.41], incl	7	238 [1640]	268 [1850]
Over 0.095 [2.41] to 0.105 [2.67], incl	5	232 [1600]	262 [1805]
Over 0.105 [2.67] to 0.115 [2.92], incl	5	227 [1565]	257 [1770]
Over 0.115 [2.92] to 0.125 [3.17], incl	5	222 [1530]	253 [1745]
Over 0.125 [3.17] to 0.135 [3.43], incl	3	217 [1495]	248 [1710]
Over 0.135 [3.43] to 0.148 [3.76], incl	3	210 [1450]	241 [1660]
Over 0.148 [3.76] to 0.162 [4.11], incl	3	205 [1415]	235 [1620]
Over 0.162 [4.11] to 0.177 [4.50], incl	3	198 [1365]	228 [1570]
Over 0.177 [4.50] to 0.192 [4.88], incl	1	194 [1335]	225 [1550]
Over 0.192 [4.88] to 0.207 [5.26], incl	1	188 [1295]	220 [1515]
Over 0.207 [5.26] to 0.225 [5.72], incl	1	182 [1255]	214 [1475]
Over 0.225 [5.72] to 0.250 [6.35], incl	1	175 [1205]	205 [1415]
Over 0.250 [6.35] to 0.278 [7.06], incl	1	168 [1160]	198 [1365]
Over 0.278 [7.06] to 0.306 [7.77], incl	1	161 [1110]	192 [1325]
Over 0.306 [7.77] to 0.331 [8.41], incl	1	155 [1070]	186 [1280]
Over 0.331 [8.41] to 0.362 [9.19], incl	1	150 [1035]	180 [1240]
Over 0.362 [9.19] to 0.394 [10.00], incl	1	145 [1000]	175 [1205]
Over 0.394 [10.00] to 0.438 [11.12], incl	1	140 [965]	170 [1170]
Over 0.438 [11.12] to 0.500 [12.70], incl	1	135 [930]	165 [1140]
Over 0.500 [12.70]		130 [895]	160 [1105]

^A When wire is specified in straightened and cut lengths, the minimum tensile strength shall be 90 % of the values listed in the table.

TABLE 6 Tensile Strength Requirements for Types 305, 316, 321, and 347^A

Diameter, in. [mm]	Bend Test Minimum Number of Bends	ksi [MPa]	
		min	max
Up to 0.010 [0.25], incl	...	245 [1690]	275 [1895]
Over 0.010 [0.25] to 0.015 [0.38], incl	...	240 [1655]	270 [1860]
Over 0.015 [0.38] to 0.024 [0.61], incl	...	235 [1620]	265 [1825]
Over 0.024 [0.61] to 0.041 [1.04], incl	8	235 [1620]	265 [1825]
Over 0.041 [1.04] to 0.047 [1.19], incl	8	230 [1585]	260 [1790]
Over 0.047 [1.19] to 0.054 [1.37], incl	8	225 [1550]	255 [1760]
Over 0.054 [1.37] to 0.062 [1.57], incl	7	220 [1515]	250 [1725]
Over 0.062 [1.57] to 0.072 [1.83], incl	7	215 [1480]	245 [1690]
Over 0.072 [1.82] to 0.080 [2.03], incl	7	210 [1450]	240 [1655]
Over 0.080 [2.03] to 0.092 [2.34], incl	7	205 [1415]	235 [1620]
Over 0.092 [2.34] to 0.105 [2.67], incl	5	200 [1380]	230 [1585]
Over 0.105 [2.67] to 0.120 [3.05], incl	5	195 [1345]	225 [1550]
Over 0.120 [3.05] to 0.148 [3.76], incl	3	185 [1275]	215 [1480]
Over 0.148 [3.76] to 0.166 [4.22], incl	3	180 [1240]	210 [1450]
Over 0.166 [4.22] to 0.177 [4.50], incl	3	170 [1170]	200 [1380]
Over 0.177 [4.50] to 0.207 [5.26], incl	1	160 [1105]	190 [1310]
Over 0.207 [5.26] to 0.225 [5.72], incl	1	155 [1070]	185 [1275]
Over 0.225 [5.72] to 0.250 [6.35], incl	1	150 [1035]	180 [1240]
Over 0.250 [6.35] to 0.312 [7.92], incl	1	140 [965]	170 [1170]
Over 0.312 [7.92] to 0.375 [9.53], incl	1	135 [930]	165 [1140]
Over 0.375 [9.53] to 0.500 [12.70], incl		130 [895]	160 [1105]
Over 0.500 [12.70]		125 [860]	155 [1070]

^A When wire is specified in straightened and cut lengths, the minimum tensile strength shall be 90 % of the values listed in the table.

TABLE 7 Tensile Strength Requirements for Grade XM-28^A

Diameter, in. [mm]	ksi [MPa]	
	min	max
Up to 0.009 [0.23], incl	325 [2240]	355 [2450]
Over 0.009 [0.23] to 0.010 [0.25], incl	320 [2205]	350 [2415]
Over 0.010 [0.25] to 0.011 [0.28], incl	318 [2195]	348 [2400]
Over 0.011 [0.28] to 0.012 [0.30], incl	316 [2180]	346 [2385]
Over 0.012 [0.30] to 0.013 [0.33], incl	314 [2165]	344 [2370]
Over 0.013 [0.33] to 0.014 [0.36], incl	312 [2150]	342 [2360]
Over 0.014 [0.36] to 0.015 [0.38], incl	310 [2135]	340 [2345]
Over 0.015 [0.38] to 0.016 [0.41], incl	308 [2125]	338 [2330]
Over 0.016 [0.41] to 0.017 [0.43], incl	306 [2110]	336 [2315]
Over 0.017 [0.43] to 0.018 [0.46], incl	304 [2095]	334 [2305]
Over 0.018 [0.46] to 0.020 [0.51], incl	300 [2070]	330 [2275]
Over 0.020 [0.51] to 0.022 [0.56], incl	296 [2040]	326 [2250]
Over 0.022 [0.56] to 0.024 [0.61], incl	292 [2015]	322 [2220]
Over 0.024 [0.61] to 0.026 [0.66], incl	289 [1995]	319 [2200]
Over 0.026 [0.66] to 0.028 [0.71], incl	286 [1970]	316 [2180]
Over 0.028 [0.71] to 0.032 [0.81], incl	282 [1945]	312 [2150]
Over 0.032 [0.81] to 0.037 [0.94], incl	277 [1910]	307 [2120]
Over 0.037 [0.94] to 0.041 [1.04], incl	273 [1880]	303 [2090]
Over 0.041 [1.04] to 0.047 [1.19], incl	270 [1860]	300 [2070]
Over 0.047 [1.19] to 0.054 [1.37], incl	265 [1825]	295 [2035]
Over 0.054 [1.37] to 0.087 [2.21], incl	260 [1795]	290 [2000]
Over 0.087 [2.21] to 0.120 [3.05], incl	255 [1760]	285 [1965]
Over 0.120 [3.05] to 0.166 [4.22], incl	250 [1725]	280 [1930]
Over 0.166 [4.22] to 0.192 [4.88], incl	240 [1655]	270 [1860]
Over 0.192 [4.88] to 0.225 [5.72], incl	230 [1585]	260 [1795]
Over 0.225 [5.72] to 0.278 [7.06], incl	215 [1480]	245 [1690]
Over 0.278 [7.06] to 0.331 [8.41], incl	200 [1380]	230 [1585]
Over 0.331 [8.41] to 0.394 [10.00], incl	185 [1275]	215 [1480]
Over 0.394 [10.00] to 0.500 [12.70], incl	160 [1105]	190 [1310]

^A When wire is specified in straightened and cut lengths, the minimum tensile strength shall be 85 % of the values listed in the table.

TABLE 8 Tensile Strength Requirement for Grade S20430

Diameter, in. [mm]	ksi [MPa]	
	min	max
Over 0.080 [2.03] to 0.095 [2.41], incl	230 [1585]	260 [1795]
Over 0.095 [2.41] to 0.105 [2.67], incl	215 [1480]	245 [1690]

TABLE 9 Tensile Strength Requirements for S30151^A

Diameter, in. [mm]	ksi [MPa]		
	min	max	
0.0059 [0.15] to 0.0079 [0.20], incl	341 [2352]	393 [2708]	
Over 0.0079 [0.20] to 0.012 [0.30], incl	333 [2297]	384 [2643]	
Over 0.012 [0.30] to 0.016 [0.40], incl	326 [2250]	376 [2590]	
Over 0.016 [0.40] to 0.020 [0.50], incl	318 [2199]	367 [2531]	
Over 0.020 [0.50] to 0.026 [0.65], incl	311 [2148]	359 [2472]	
Over 0.026 [0.65] to 0.031 [0.80], incl	304 [2101]	351 [2419]	
Over 0.031 [0.80] to 0.039 [1.00], incl	296 [2040]	342 [2354]	
Over 0.039 [1.00] to 0.049 [1.25], incl	289 [1995]	334 [2300]	
Over 0.049 [1.25] to 0.059 [1.50], incl	283 [1953]	326 [2250]	
Over 0.059 [1.50] to 0.069 [1.75], incl	275 [1895]	317 [2183]	
Over 0.069 [1.75] to 0.079 [2.00], incl	268 [1850]	309 [2130]	
Over 0.079 [2.00] to 0.098 [2.50], incl	253 [1748]	292 [2015]	
Over 0.098 [2.50] to 0.118 [3.00], incl	246 [1695]	284 [1959]	
Over 0.118 [3.00] to 0.138 [3.50], incl	239 [1650]	276 [1900]	
Over 0.138 [3.50] to 0.167 [4.25], incl	231 [1599]	267 [1840]	
Over 0.167 [4.25] to 0.197 [5.00], incl	225 [1550]	260 [1787]	
Over 0.197 [5.00] to 0.236 [6.00], incl	217 [1495]	250 [1723]	
Over 0.236 [6.00] to 0.276 [7.00], incl	210 [1450]	243 [1670]	
Over 0.276 [7.00] to 0.335 [8.50], incl	202 [1399]	234 [1611]	

^A Tensile requirements for cold drawn wire. By heat treating the material at 660–800°F [350–425°C] for 0.5–4 h, the tensile strength will increase by approximately 22–44 ksi [150–300 MPa]. If a shorter heat treatment time is used, the effect will be less.

TABLE 10 Tensile Strength Requirements for S20230

Diameter, in. [mm]	ksi [MPa]	
	min	max
0.0059 [0.15] to 0.0079 [0.20], incl	319 [2200]	367 [2530]
Over 0.0079 [0.20] to 0.012 [0.30], incl	312 [2150]	358 [2470]
Over 0.012 [0.30] to 0.016 [0.40], incl	305 [2105]	351 [2420]
Over 0.016 [0.40] to 0.020 [0.50], incl	297 [2045]	341 [2355]
Over 0.020 [0.50] to 0.026 [0.65], incl	290 [2000]	334 [2300]
Over 0.026 [0.65] to 0.031 [0.80], incl	283 [1950]	325 [2245]
Over 0.031 [0.80] to 0.039 [1.00], incl	276 [1905]	318 [2190]
Over 0.039 [1.00] to 0.049 [1.25], incl	269 [1855]	309 [2130]
Over 0.049 [1.25] to 0.059 [1.50], incl	261 [1800]	301 [2075]
Over 0.059 [1.50] to 0.069 [1.75], incl	254 [1750]	292 [2015]
Over 0.069 [1.75] to 0.079 [2.00], incl	246 [1700]	284 [1955]
Over 0.079 [2.00] to 0.098 [2.50], incl	239 [1650]	275 [1895]
Over 0.098 [2.50] to 0.118 [3.00], incl	232 [1595]	266 [1835]
Over 0.118 [3.00] to 0.138 [3.50], incl	224 [1545]	258 [1780]
Over 0.138 [3.50] to 0.167 [4.25], incl	218 [1500]	250 [1725]
Over 0.167 [4.25] to 0.197 [5.00], incl	216 [1490]	248 [1710]
Over 0.197 [5.00] to 0.236 [6.00], incl	203 [1400]	233 [1610]
Over 0.236 [6.00] to 0.276 [7.00], incl	195 [1345]	225 [1550]
Over 0.276 [7.00] to 0.335 [8.50], incl	189 [1300]	217 [1500]
Over 0.335 [8.50] to 0.394 [10.0], incl	181 [1250]	209 [1440]

TABLE 11 Tensile Strength Requirements for S32205^A

Diameter, in. [mm]	Cold Drawn, ksi [MPa]	
	Min.	Max.
0.0055 [0.14] to 0.0079 [0.20], incl	312 [2150]	341 [2350]
Over 0.0079 [0.20] to 0.012 [0.30], incl	305 [2100]	334 [2300]
Over 0.012 [0.30] to 0.020 [0.50], incl	291 [2000]	320 [2200]
Over 0.020 [0.50] to 0.031 [0.80], incl	276 [1900]	305 [2100]
Over 0.031 [0.80] to 0.049 [1.25], incl	262 [1800]	291 [2000]
Over 0.049 [1.25] to 0.079 [2.00], incl	247 [1700]	276 [1900]
Over 0.079 [2.00] to 0.138 [3.50], incl	225 [1550]	254 [1750]
Over 0.138 [3.50] to 0.197 [5.00], incl	211 [1450]	240 [1650]
Over 0.197 [5.00] to 0.314 [8.00], incl	196 [1350]	225 [1550]

^A Tensile requirements for cold drawn, as-delivered wire. Tensile strength can be increased by 29 ksi [200 MPa] up to 65 ksi [450 MPa] by tempering depending on tensile and tempering conditions. Recommendations: 840°F [450°C]/1–3 h for batch tempering; 950°F [500°C] for 3 to 10 minutes in a continuous conveyor furnace. Shorter times may result in uneven tempering.

During storage, the tensile strength will increase somewhat due to aging. Depending on the storage conditions, the tensile strength can increase by 0 – 12 ksi [0 -80 MPa].

TABLE 12 Tensile Strength Requirements for S32205 HS (High Strength)^A

Diameter, in. [mm]	Cold Drawn, ksi [MPa]	
	Min.	Max.
0.0079 [0.20] to 0.028 [0.70], incl	344 [2370]	396 [2730]
Over 0.028 [0.70] to 0.031 [0.80], incl	324 [2230]	372 [2570]
Over 0.031 [0.80] to 0.040 [1.00], incl	311 [2140]	357 [2460]
Over 0.040 [1.00] to 0.059 [1.50], incl	303 [2090]	349 [2410]
Over 0.059 [1.50] to 0.079 [2.00], incl	290 [2000]	334 [2300]
Over 0.079 [2.00] to 0.098 [2.50], incl	276 [1910]	318 [2190]
Over 0.098 [2.50] to 0.118 [3.00], incl	270 [1860]	310 [2140]
Over 0.118 [3.00] to 0.138 [3.50], incl	263 [1810]	303 [2090]
Over 0.138 [3.50] to 0.157 [4.00], incl	257 [1770]	295 [2030]
Over 0.157 [4.00] to 0.177 [4.50], incl	249 [1720]	287 [1980]
Over 0.177 [4.50] to 0.197 [5.00], incl	243 [1670]	279 [1930]

^A Tensile requirements for high strength cold drawn, as delivered wire. Tensile strength can be increased by 29 ksi [200 MPa] up to 65 ksi [450 MPa] by tempering depending on tensile and tempering conditions. Recommendations: 840°F [450°C]/1–3 h for batch tempering; 950°F [500°C] for 3-10 minutes in a continuous conveyor furnace. Shorter times may result in uneven tempering.

During storage, the tensile strength will increase somewhat due to aging. Depending on the storage conditions, the tensile strength can increase by 0 – 12 ksi [0 -80 MPa].

TABLE 13 Arbor Diameter Size for Uniformity Test

Wire Diameter, in. [mm]	Arbor Diameter, in. [mm]
0.034 [0.85] and under	0.102 [2.60]
Over 0.034 [0.85] to 0.045 [1.20], incl	0.145 [3.70]
Over 0.045 [1.20] to 0.055 [1.40], incl	0.212 [5.40]
Over 0.055 [1.40] to 0.125 [3.20], incl	0.250 [6.40]
Over 0.125 [3.20] to 0.180 [4.60], incl	0.350 [9.00]

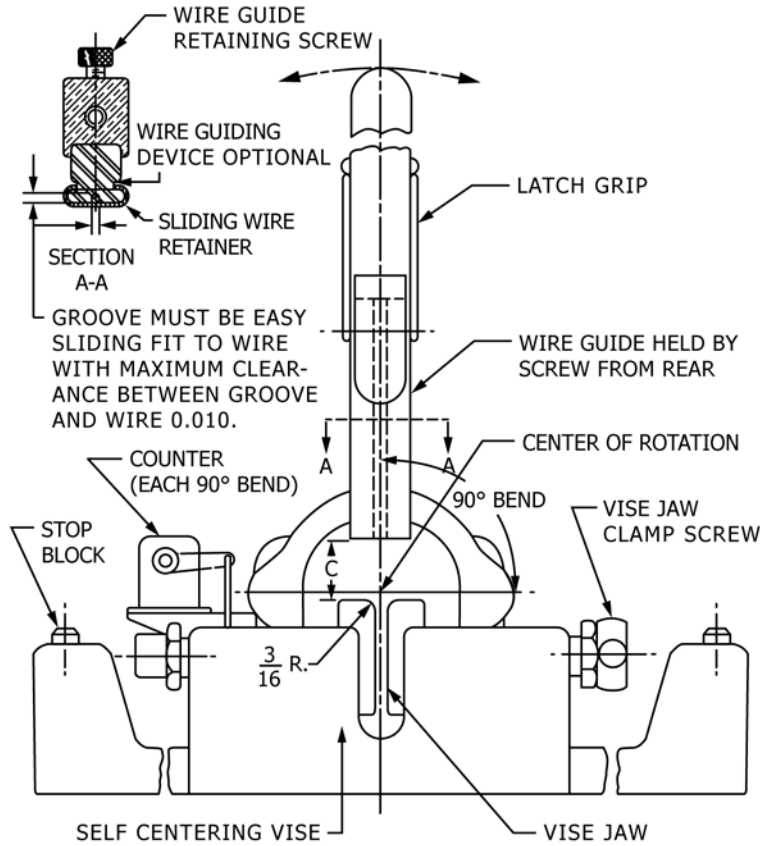

Diameter of Wire, in. [mm]	Clearance C ± 0.005, in. [mm]
Over 0.026 to 0.105 [0.65 to 2.70], incl	0.688 [17.50]
Over 0.105 to 0.162 [2.70 to 4.10], incl	0.813 [20.50]
Over 0.162 to 0.180 [4.10 to 4.60], incl	0.938 [24.00]

FIG. 1 Schematic Arrangement of Bending Machine

SUPPLEMENTARY REQUIREMENTS

Unless otherwise specified in the purchase order, the following supplementary requirements shall apply when this specification is used in government procurement of Type 631 spring wire up to and including 0.162 in. [4.11 mm] in diameter.

S1. Wrapping Test

S.1.1 A wire specimen shall be wrapped five complete turns around a mandrel equal to the diameter of the wire without any surface breaks or cracks occurring in the wire. One specimen shall be taken from every ten coils in the lot.

S2. Surface Examination

S2.1 A wire specimen shall be etched electrolytically in a 75 % phosphoric acid solution with a current density of 1A/in². for a sufficient time to remove up to 1 % of the diameter. After etching the surface of the wire specimen it shall be examined

under a 10 power microscope for splits, seams, pits, die marks, scratches, or other imperfections tending to impair the fatigue resistance of springs. Appropriate higher magnification should

be used for sizes below 0.125 in. [3.17 mm]. Lubricating coatings, which are insoluble in acid etch solution, shall be removed before etching.

SUMMARY OF CHANGES

Committee A01 has identified the location of selected changes to this standard since the last issue (A313/A313M – 10^{e1}) that may impact the use of this standard. (Approved Oct. 1, 2013.)

- (1) Added new grade UNS S32205 to **Table 1** and **Table 11** and **Table 12** and Sections **5.1** and **7.1.10**. Renumbered **Table 13** in **7.3.1**.
- (2) Added tensile strength ordering option to 3.1.7.
- (3) Added austenitic-ferritic duplex stainless steel to keywords.

ASTM International takes no position respecting the validity of any patent rights asserted in connection with any item mentioned in this standard. Users of this standard are expressly advised that determination of the validity of any such patent rights, and the risk of infringement of such rights, are entirely their own responsibility.

This standard is subject to revision at any time by the responsible technical committee and must be reviewed every five years and if not revised, either reapproved or withdrawn. Your comments are invited either for revision of this standard or for additional standards and should be addressed to ASTM International Headquarters. Your comments will receive careful consideration at a meeting of the responsible technical committee, which you may attend. If you feel that your comments have not received a fair hearing you should make your views known to the ASTM Committee on Standards, at the address shown below.

This standard is copyrighted by ASTM International, 100 Barr Harbor Drive, PO Box C700, West Conshohocken, PA 19428-2959, United States. Individual reprints (single or multiple copies) of this standard may be obtained by contacting ASTM at the above address or at 610-832-9585 (phone), 610-832-9555 (fax), or service@astm.org (e-mail); or through the ASTM website (www.astm.org). Permission rights to photocopy the standard may also be secured from the ASTM website (www.astm.org/COPYRIGHT/).