

INTERNATIONAL STANDARD

ISO
13861

First edition
2000-04-15

Machinery for forestry — Wheeled skidders — Terms, definitions and commercial specifications

*Matériel forestier — Débusqueuses à roues — Termes, définitions et
spécifications commerciales*



Reference number
ISO 13861:2000(E)

© ISO 2000

PDF disclaimer

This PDF file may contain embedded typefaces. In accordance with Adobe's licensing policy, this file may be printed or viewed but shall not be edited unless the typefaces which are embedded are licensed to and installed on the computer performing the editing. In downloading this file, parties accept therein the responsibility of not infringing Adobe's licensing policy. The ISO Central Secretariat accepts no liability in this area.

Adobe is a trademark of Adobe Systems Incorporated.

Details of the software products used to create this PDF file can be found in the General Info relative to the file; the PDF-creation parameters were optimized for printing. Every care has been taken to ensure that the file is suitable for use by ISO member bodies. In the unlikely event that a problem relating to it is found, please inform the Central Secretariat at the address given below.

© ISO 2000

All rights reserved. Unless otherwise specified, no part of this publication may be reproduced or utilized in any form or by any means, electronic or mechanical, including photocopying and microfilm, without permission in writing from either ISO at the address below or ISO's member body in the country of the requester.

ISO copyright office
Case postale 56 • CH-1211 Geneva 20
Tel. + 41 22 749 01 11
Fax + 41 22 734 10 79
E-mail copyright@iso.ch
Web www.iso.ch

Printed in Switzerland

Foreword

ISO (the International Organization for Standardization) is a worldwide federation of national standards bodies (ISO member bodies). The work of preparing International Standards is normally carried out through ISO technical committees. Each member body interested in a subject for which a technical committee has been established has the right to be represented on that committee. International organizations, governmental and non-governmental, in liaison with ISO, also take part in the work. ISO collaborates closely with the International Electrotechnical Commission (IEC) on all matters of electrotechnical standardization.

International Standards are drafted in accordance with the rules given in the ISO/IEC Directives, Part 3.

Draft International Standards adopted by the technical committees are circulated to the member bodies for voting. Publication as an International Standard requires approval by at least 75 % of the member bodies casting a vote.

Attention is drawn to the possibility that some of the elements of this International Standard may be the subject of patent rights. ISO shall not be held responsible for identifying any or all such patent rights.

International Standard ISO 13861 was prepared by Technical Committee ISO/TC 23, *Tractors and machinery for agriculture and forestry*, Subcommittee SC 15, *Machinery for forestry*.

Machinery for forestry — Wheeled skidders — Terms, definitions and commercial specifications

1 Scope

This International Standard specifies terminology and required information as a general framework for identifying and describing the main dimensions and features of wheeled skidders.

It is applicable to articulated wheeled cable and grapple skidders as defined in ISO 6814.

NOTE The terminology and requirements given in this International Standard will not necessarily all apply to a specific machine. Machines may be characterized by the dimensions and features which are relevant to them.

2 Normative reference

The following normative document contains provisions which, through reference in this text, constitute provisions of this International Standard. For dated references, subsequent amendments to, or revisions of, any of these publications do not apply. However, parties to agreements based on this International Standard are encouraged to investigate the possibility of applying the most recent edition of the normative document indicated below. For undated references, the latest edition of the normative document referred to applies. Members of ISO and IEC maintain registers of currently valid International Standards.

ISO 6814:2000, *Machinery for forestry — Mobile and self-propelled machinery — Terms, definitions and classification*.

3 Terms definitions and classification

See Figures 1 to 6. The figures are for illustrative purposes only and are not intended to depict specific machines.

All dimensions are with the axles parallel, unless otherwise specified.

3.1 General

3.1.1

right (left) hand

operator's right hand side (left hand side) when facing in the normal direction of travel and with the machine in its primary functional mode

3.1.2

front/rear

front or rear of the operator, respectively, when facing in the normal direction of travel and with the machine in its primary functional mode

3.1.3

ground reference plane

GRP

hard, flat, horizontal surface on which the machine is placed for measurements

3.2 Masses

3.2.1

normal operating mass

total mass of the machine as specified, fully serviced, with full fluid levels and a 75 kg operator

3.2.2

maximum operating mass

total mass of the machine as specified, fully serviced, with full fluid levels and a 75 kg operator, including all machine options with the largest tyre or hydro-inflation combination and the manufacturer's maximum specified load

3.2.3

load per axle

standard and maximum mass on both the front and rear axles

3.3 Main machine dimensions

3.3.1

total frame length

l_1

horizontal distance between the vertical planes perpendicular to the longitudinal axis passing through the farthest points on the front and rear of the machine, including fenders, tow bars, butt plate, etc., but excluding the fairlead, blade, or grapple

3.3.2

overall length

l_2

horizontal distance from a vertical plane touching the forwardmost point of the machine, blade positioned to give maximum forward reach, to a vertical plane touching the rearmost point of the machine

3.3.3

wheelbase

l_3

horizontal distance from the centre of the front axle or front bogie axle assembly to the centre of the rear axle or rear bogie axle assembly when both axles are perpendicular to the longitudinal axis

3.3.4

articulation joint to maximum blade arc

l_4

horizontal distance from the centreline of the articulation joint to a vertical line tangent to the arc of the blade's lower edge as it passes from its maximum height h_3 to the lowest blade position h_4

3.3.5

articulation joint to front of machine

l_5

horizontal distance from the centreline of the articulation joint to a vertical plane touching the farthest point forward, blade excluded

3.3.6

articulation joint to front axle

l_6

horizontal distance from the centreline of the articulation joint to the centre of the front axle or front bogie axle assembly

3.3.7**overall height** h_1

vertical distance between the GRP and a horizontal plane passing through the highest point of the machine

3.3.8**blade height** h_2

vertical distance from the lower edge, resting on the GRP, to the top of the blade, decking lugs excluded

3.3.9**maximum blade lift of lower edge** h_3

maximum vertical height to which the lower edge of the blade can be raised from the GRP

3.3.10**lowest blade position** h_4

vertical distance from the GRP to the blade's lower edge with blade at its lowest position

3.3.11**ground clearance** h_5

vertical distance from the GRP to the lowest point of the machine centre portion, i.e. 25 % of the tread to either side of the longitudinal centreline

3.3.12**ground clearance at articulation joint** h_6

vertical distance from the GRP to the lowest point at the articulation joint

3.3.13**loaded tire radius** r_1

vertical distance from the GRP to the horizontal centre of the axle with the machine at normal operating mass

3.3.14**main fairlead roller height** h_7

vertical distance from the horizontal centre of the main fairlead roller to the horizontal centre of the axle

3.3.15**winch height** h_8

vertical distance from the horizontal centre of the winch drum to the horizontal centre of the axle

3.3.16**rear axle to main fairlead roller** l_7

horizontal distance from the vertical centre of the rear axle to the vertical centre of the main fairlead roller

3.3.17**main fairlead roller diameter** d_1

diameter of main fairlead roller at its mid-length position

3.3.18

overall width

w_1

horizontal distance between two vertical planes parallel to the longitudinal axis of the machine and passing through the farthest points on the two sides of this axis

3.3.19

tread

w_2

horizontal distance between two parallel vertical planes passing through the centreline of the tires on an axle

3.3.20

frame oscillation

a_1

angle that one frame will rotate from a horizontal datum, in both directions, without rotating the other frame, measured in degrees

3.3.21

axle oscillation

a_2

angle that one axle will rotate from a horizontal datum, in both directions, without rotating either frame, measured in degrees

3.3.22

clearance circle

d_2

diameter of the smallest circle that the outermost point on the machine will describe when turning, brakes unapplied, blade in travel position, unloaded

3.3.23

angle of articulation

a_3

maximum angle of frame steering movement from the straight ahead position between longitudinal centrelines of the front and rear frames, measured in degrees

3.3.24

blade width

w_3

horizontal distance between the outer edges of the blade

3.4 Grapple dimensions

3.4.1

grapple reach

l_1, l_2, l_3, l_4

horizontal distance from the vertical centre of the rear axle to the vertical centre of the grapple pivot under the following conditions:

- l_1 with the pivot in the highest, fully extended position;
- l_2 with the pivot in the lowest, fully extended position;
- l_3 with the pivot in the highest, fully retracted position;
- l_4 with the pivot in the lowest, fully retracted position

3.4.2**grapple lift***hh₁, hh₂, hh₃, hh₄*

vertical distance from the horizontal centre of the rear axle to the horizontal centre of the grapple pivot under the following conditions:

- *hh₁* with the pivot in the highest, fully retracted position;
- *hh₂* with the pivot in the highest, fully extended position;
- *hh₃* with the pivot in the lowest, fully retracted position;
- *hh₄* with the pivot in the lowest, fully extended position

3.4.3**boom rotation***aa₁*

angle in degrees from the longitudinal axis of the machine to the longitudinal centre of the boom at maximum swing position

3.4.4**rear axle to main swing boom pivot***ll₅*

horizontal distance from the vertical centre of the rear axle to the vertical centre of the main swing boom pivot

3.4.5**grapple height***hh₅, hh₆, hh₇*

vertical distance from the centre of the upper pivot to the lowest point of the grapple arms under the following conditions:

- *hh₅* with the grapple fully open;
- *hh₆* with the grapple in tip-to-tip position;
- *hh₇* with the grapple fully closed

3.4.6**maximum grapple opening***ll₆*

horizontal distance between the tips of the grapple arms the grapple fully open

3.4.7**area of grapple opening***A*

cross-sectional area of the grapple opening in the tip-to-tip position

3.4.8**minimum log size***dd₁*

smallest diameter of log which the grapple can hold in a fully closed position

3.4.9**grapple rotation**

number of degrees through which the grapple can rotate

3.5 Grapple configurations

3.5.1

single function

configuration in which the grapple support assembly consists of a single arch and a pair of hydraulic cylinders allowing the grapple pivot to move through a fixed arc

3.5.2

dual function

configuration in which the grapple support assembly consists of a boom, arch, and two sets of hydraulic cylinders allowing the grapple pivot to describe a range of motion in a vertical longitudinal plane

3.5.3

swing boom

configuration in which the grapple support consists of a boom assembly which allows both horizontal and vertical grapple movement

3.6 Butt plate dimensions

3.6.1

rear axle to butt plate

l_7

horizontal distance from the centre of the rear axle to the rearward face of the butt plate

3.6.2

length of load support

l_8

horizontal distance from the rearward face of the butt plate to the rearmost edge of the load support

3.6.3

lowest butt plate position

hh_8

vertical distance from the GRP to the lowest edge of the butt plate with the butt plate fully lowered

4 Required information

In addition to the identification of relevant dimensions and features as defined in clause 3, the following information shall be supplied where appropriate:

- tyre size;
- ply rating;
- inflation pressure;
- possible hydro-inflation;
- maximum and minimum for adjustable dimensions, e.g. main fairlead roller height (3.3.14) and rear axle to main fairlead roller length (3.3.16);
- unequal front/rear or left/right for asymmetrical dimensions, e.g. tread (3.3.19), angle of articulation (3.3.23), boom rotation (3.4.3).

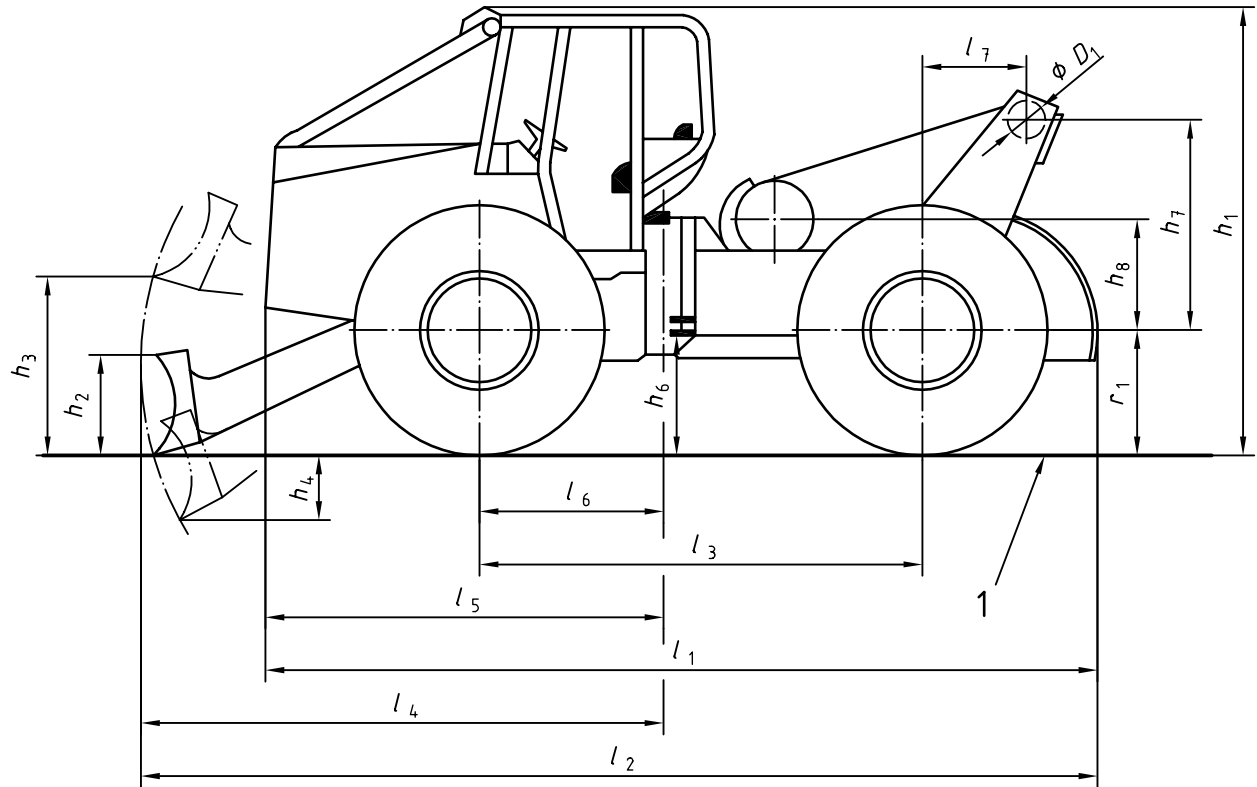

Key

- 1 GRP

Figure 1 — Articulated rubber-tired skidder

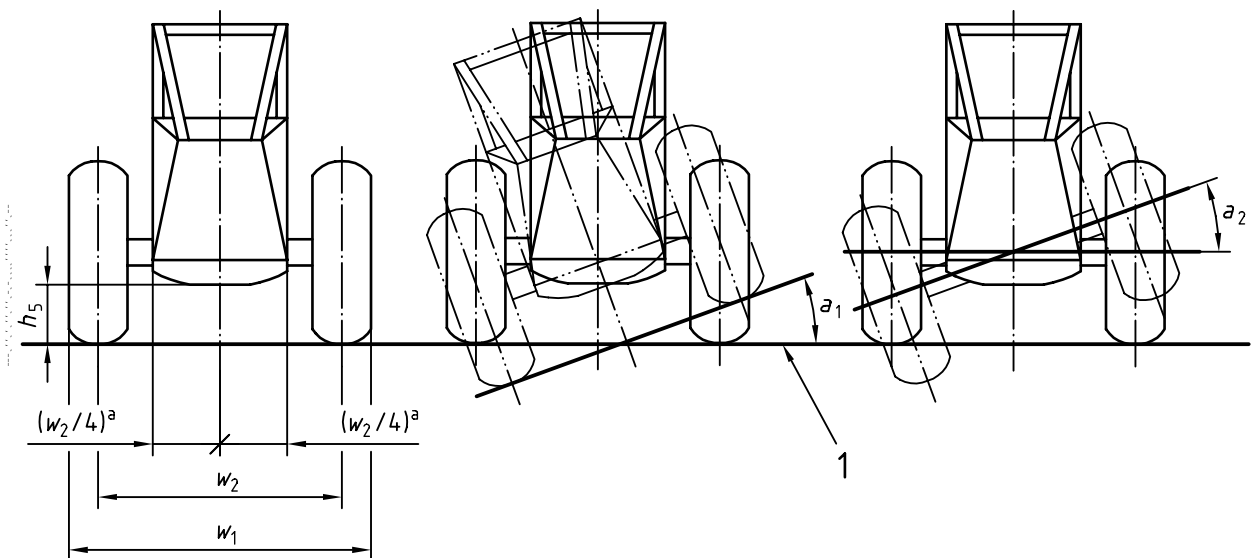

Key

- 1 GRP

- a Used for definition h_5 only

Figure 2 — Tread, ground clearance and oscillation

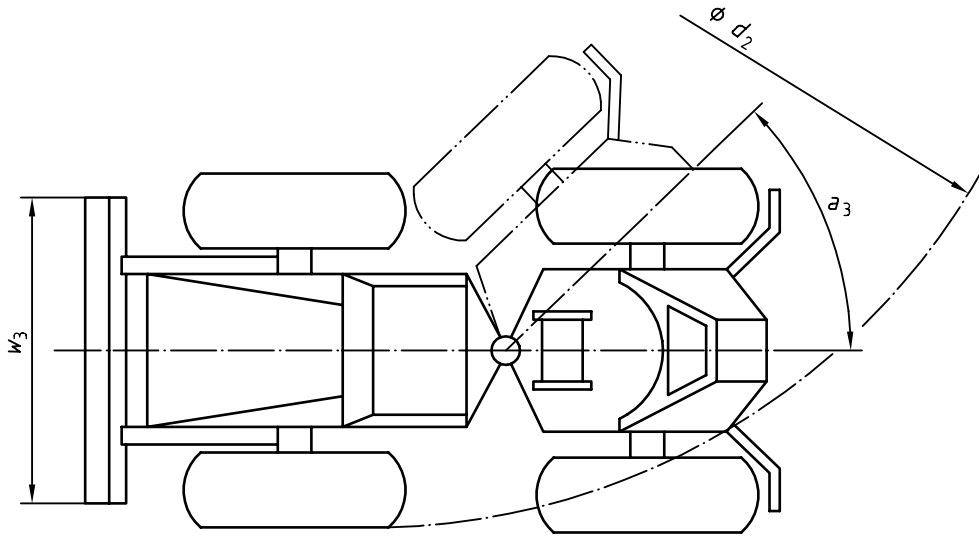
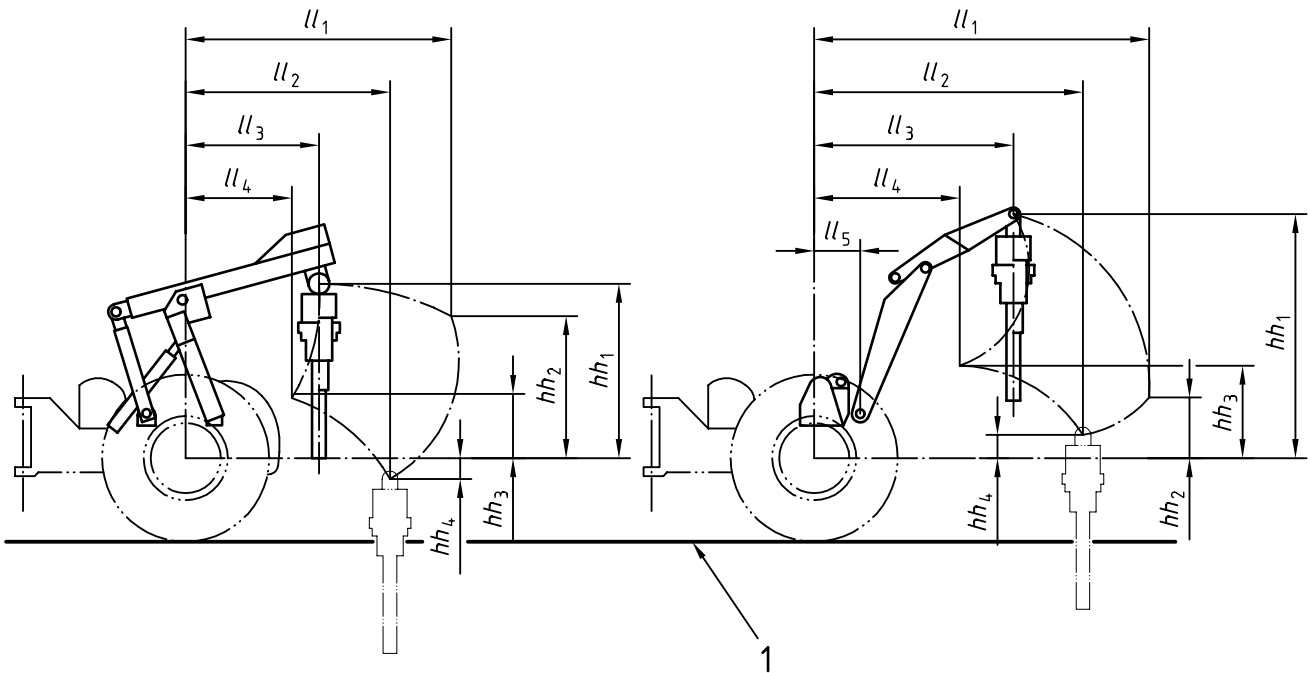
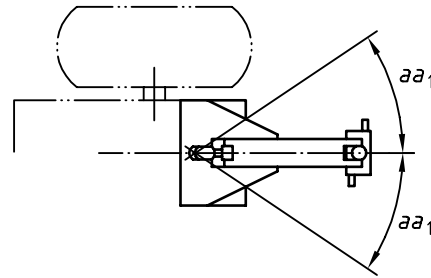

Figure 3 — Steering



Key

- 1 GRP

Figure 4 — Grapple boom assemblies

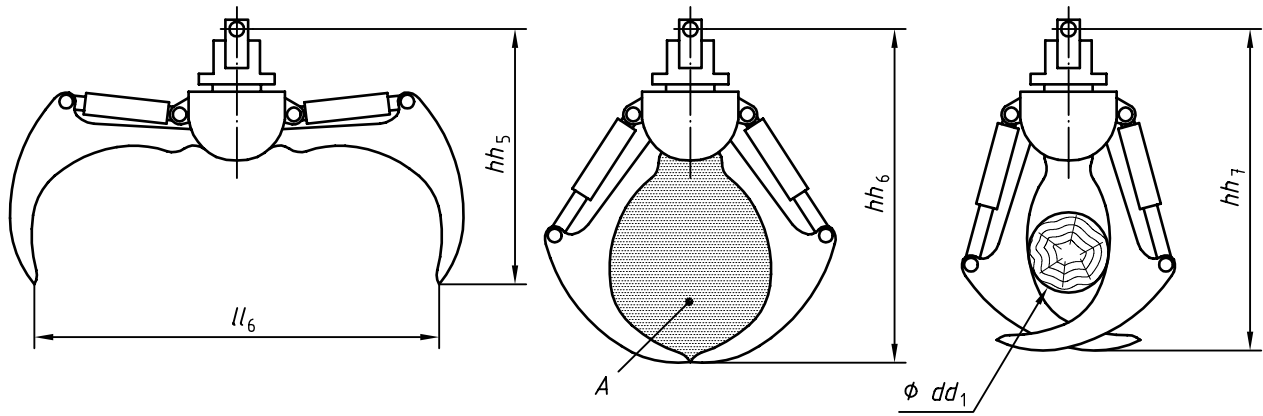
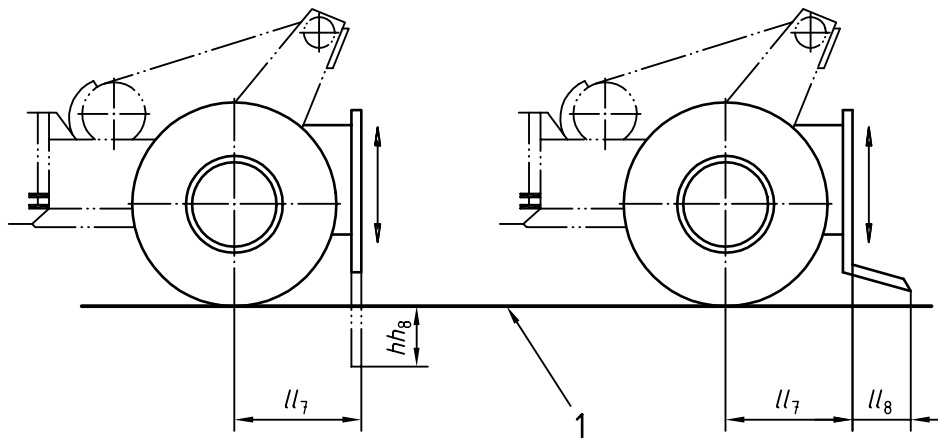

Figure 5 — Grapple specifications



Key

- 1 GRP

Figure 6 — Movable butt plate dimensions

ICS 01.040.65; 65.060.80

Price based on 9 pages

© ISO 2000 – All rights reserved